

U.S. General[®]

MOTORCYCLE STAND WHEEL CHOCK

Model 97071

SET UP AND OPERATING INSTRUCTIONS



Diagrams within this manual may not be drawn proportionally.

Due to continuing improvements, actual product may differ slightly from the product described herein.

Distributed exclusively by Harbor Freight Tools[®].

3491 Mission Oaks Blvd., Camarillo, CA 93011

Visit our website at: <http://www.harborfreight.com>



**Read this material before using this product.
Failure to do so can result in serious injury.
SAVE THIS MANUAL.**

Copyright[®] 2007 by Harbor Freight Tools[®]. All rights reserved. No portion of this manual or any artwork contained herein may be reproduced in any shape or form without the express written consent of Harbor Freight Tools.

For technical questions or replacement parts, please call 1-800-444-3353.

SAVE THIS MANUAL

Keep this manual for the safety warnings and precautions, assembly, operating, inspection, maintenance and cleaning procedures. Write the product's serial number in the back of the manual near the assembly diagram (or month and year of purchase if product has no number). Keep this manual and the receipt in a safe and dry place for future reference.



WARNING! Read all instructions

Failure to follow all instructions listed below may result in serious injury.

SAVE THESE INSTRUCTIONS

WORK AREA SAFETY

1. **Keep children and bystanders away while operating. Distractions can cause you to lose control.**
2. Keep work area clean and well lit. Cluttered or dark areas invite accidents.

PERSONAL SAFETY

1. **Wear ANSI-approved safety goggles, NIOSH-approved dust mask/respirator, and heavy-duty work gloves during installation.**
2. Stay alert and use common sense when operating. Do not use when tired or under the influence of drugs, alcohol or medication.
3. Do not overreach. Keep proper footing and balance at all times. This enables better control in unexpected situations.
4. Dress properly. Do not wear loose clothing or jewelry. Keep your hair, clothing and gloves away from moving parts. Loose clothes, jewelry or long hair can be caught in moving parts.

PRODUCT USE AND CARE

1. **This product is not a toy. Keep it out of reach of children.**
2. Use the correct product for your application. Make sure your motorcycle's wheel fits in the Motorcycle Stand. Do not modify this product or use it for a purpose for which it is not intended.
3. Check for misalignment or binding of moving parts, breakage of parts and any other condition that may affect the product's operation. If damaged, have the product repaired before use.

4. Use the product with these instructions and in the manner intended for the particular type of product, taking into account the working conditions and the work to be performed. Use of the product for operations different from those intended could result in a hazardous situation.

SERVICE

1. Have product serviced by a qualified repair person using only identical replacement parts. This will ensure that the safety of the product is maintained.
2. Maintain labels and nameplates on the product. These carry important safety information. If unreadable or missing, contact Harbor Freight Tools for a replacement.

MISCELLANEOUS

1. Do not exceed maximum load for this product (1,800 pounds). Loading a heavier motorcycle on the Stand can result in dangerous conditions to both the operator and the item loaded.
2. Always mount the Motorcycle Stand securely on level, dry surfaces that are capable of bearing the combined weight of the Stand and motorcycle.
3. Do not ride a motorcycle onto the Stand.
4. Never sit on the motorcycle while it is loaded on the Stand.
5. Do not use for aircraft purposes.
6. The warnings, precautions, and instructions discussed in this instruction manual cannot cover all possible conditions and situations that may occur. It must be understood by the operator that common sense and caution are factors which cannot be built into this product, but must be supplied by the operator.



SAVE THESE INSTRUCTIONS.

SPECIFICATIONS

Weight Capacity	1,800 Pounds
Wheel Size	16" to 26" L
Maximum Motorcycle Wheel Footprint*	3" to 5" W

* The "footprint" of the motorcycle is the total size of the tires where they contact the floor. Motorcycles come in many different designs – certain large or customized motorcycles may not work properly with this dolly. Do not modify this product to fit any motorcycle it would not normally work with.

UNPACKING

When unpacking, check to make sure that the item is intact and undamaged. If any parts are missing or broken, please call Harbor Freight Tools at the number shown on the cover of this manual as soon as possible.

SET UP INSTRUCTIONS



Read the **ENTIRE IMPORTANT SAFETY INFORMATION** section at the beginning of this manual including all text under subheadings therein before set up or use of this product.

Note: For additional information regarding the parts listed in the following pages, refer to the Assembly Diagram near the end of this manual.

Assembly

1. Measure the motorcycle wheel prior to assembly so that the Motorcycle Stand can be adjusted to fit the wheel length. The Motorcycle Stand will fit most standard motorcycles currently on the market. However, some models with especially wide tires or custom low-profile front fenders will not fit.
2. Use 2 Bolts (5) to mount the Cradle Stop (7) to the Base (9); secure with Washers (11) and Nuts (12).
3. Mount the Support Arm (6) to the front of the Base using 3 Bolts (1), Washers (11), and Nuts (12).
4. Insert Pin (10) through the mounting holes and Wheel Adapter (8); secure with Washer (4) and R Pin (3).
5. Securely tighten all hardware before use.
6. **The Motorcycle Stand must be mounted securely before use.**

Mounting in Concrete

1. Choose a location to install the Wheel Chock that is flat, level, and capable of bearing the combined weight of the Wheel Chock and the motorcycle being secured. The location should not obstruct walkways and still provide enough room to retrieve the motorcycle after it is mounted. The surface of the location should be one suitable for the mounting of heavy equipment.
2. Use the mounting holes in the Base (9) of the Stand as a template. Arrange the Base (7) in the chosen location and, using a pencil, mark where the holes are to be drilled.
3. You will need concrete anchors (not included) to secure the Base (9) to the concrete floor. Using the correct size concrete drill bit (not included), drill the mounting holes to secure the Base (9).
4. Attach the concrete anchors to the floor. Secure the Base (7) to the floor utilizing concrete anchors.

Note. Do not sit on the motorcycle when it is loaded in the Wheel Chock.

Truck Bed Mounting

1. Place the Base (9) in the desired location of the truck bed or motorcycle lift. Use the holes in the Base as a pattern to mark where to drill the holes for the hardware to mount the Stand.

Warning: Verify that the installation surface has no hidden wires, brake lines, etc. before drilling.

2. Use a power drill (not included) and a steel cutting drill bit (not included) to drill holes in the truck bed or motorcycle lift.
3. Attach the Base (9) to the truck bed utilizing the appropriate hardware (not included).

OPERATING INSTRUCTIONS



Read the **ENTIRE IMPORTANT SAFETY INFORMATION** section at the beginning of this manual including all text under subheadings therein before set up or use of this product.

1. Select the correct mounting hole for the motorcycle being loaded on the Stand, and adjust the location of the Wheel Adapter (8) to fit the tire length properly.
2. To load a motorcycle, lower the Wheel Adapter to the horizontal position and simply push the motorcycle into the Stand. The Wheel Adapter will close on the motorcycle tire, securing the bike in an upright position.

3. The motorcycle should be secured with belts or straps (not included).
4. To dismount the motorcycle, pull back firmly and steadily until the motorcycle rolls free of the Stand.

MAINTENANCE AND SERVICING

⚠ CAUTION

Damaged products can fail, causing personal injury. Do not use a damaged product. If abnormal noise or vibration occurs, have the problem corrected before further use.

Cleaning, maintenance, and lubrication

1. **BEFORE EACH USE**, inspect the general condition of the product. Check for loose screws, misalignment or binding of moving parts, cracked or broken parts, and any other condition that may affect its safe operation.
2. **AFTER USE**, clean external surfaces of the product with clean, moist cloth.

PLEASE READ THE FOLLOWING CAREFULLY

THE MANUFACTURER AND/OR DISTRIBUTOR HAS PROVIDED THE PARTS LIST AND ASSEMBLY DIAGRAM IN THIS MANUAL AS A REFERENCE TOOL ONLY. NEITHER THE MANUFACTURER OR DISTRIBUTOR MAKES ANY REPRESENTATION OR WARRANTY OF ANY KIND TO THE BUYER THAT HE OR SHE IS QUALIFIED TO MAKE ANY REPAIRS TO THE PRODUCT, OR THAT HE OR SHE IS QUALIFIED TO REPLACE ANY PARTS OF THE PRODUCT. IN FACT, THE MANUFACTURER AND/OR DISTRIBUTOR EXPRESSLY STATES THAT ALL REPAIRS AND PARTS REPLACEMENTS SHOULD BE UNDERTAKEN BY CERTIFIED AND LICENSED TECHNICIANS, AND NOT BY THE BUYER. THE BUYER ASSUMES ALL RISK AND LIABILITY ARISING OUT OF HIS OR HER REPAIRS TO THE ORIGINAL PRODUCT OR REPLACEMENT PARTS THERETO, OR ARISING OUT OF HIS OR HER INSTALLATION OF REPLACEMENT PARTS THERETO.

PARTS LIST & ASSEMBLY DIAGRAM

Part	Description	Qty	Part	Description	Qty
1	Bolt M10x45	3	7	Cradle Stop	1
2	Pad	2	8	Wheel Adapter	1
3	R-pin	2	9	Base	1
4	Washer Φ 12	2	10	Pin	1
5	Bolt M10x25	2	11	Washer M10	5
6	Support Arm	1	12	Nut M10	5

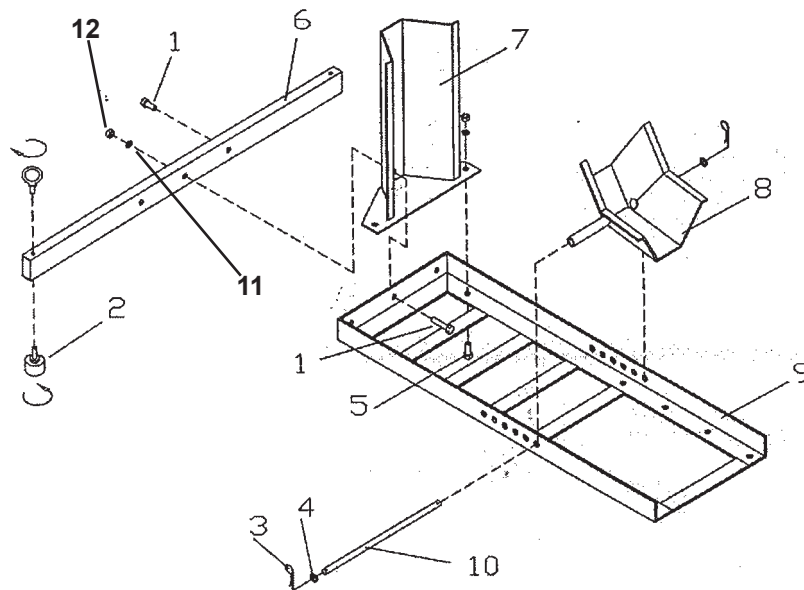

LIMITED 90 DAY WARRANTY

Harbor Freight Tools Co. makes every effort to assure that its products meet high quality and durability standards, and warrants to the original purchaser that this product is free from defects in materials and workmanship for the period of 90 days from the date of purchase. This warranty does not apply to damage due directly or indirectly, to misuse, abuse, negligence or accidents, repairs or alterations outside our facilities, criminal activity, improper installation, normal wear and tear, or to lack of maintenance. We shall in no event be liable for death, injuries to persons or property, or for incidental, contingent, special or consequential damages arising from the use of our product. Some states do not allow the exclusion or limitation of incidental or consequential damages, so the above limitation of exclusion may not apply to you. THIS WARRANTY IS EXPRESSLY IN LIEU OF ALL OTHER WARRANTIES, EXPRESS OR IMPLIED, INCLUDING THE WARRANTIES OF MERCHANTABILITY AND FITNESS.

To take advantage of this warranty, the product or part must be returned to us with transportation charges prepaid. Proof of purchase date and an explanation of the complaint must accompany the merchandise. If our inspection verifies the defect, we will either repair or replace the product at our election or we may elect to refund the purchase price if we cannot readily and quickly provide you with a replacement. We will return repaired products at our expense, but if we determine there is no defect, or that the defect resulted from causes not within the scope of our warranty, then you must bear the cost of returning the product.

This warranty gives you specific legal rights and you may also have other rights which vary from state to state.

3491 Mission Oaks Blvd. • PO Box 6009 • Camarillo, CA 93011 • (800) 444-3353

Record Product's Serial Number Here: _____

Note: If product has no serial number, record month and year of purchase instead.

Note: Some parts are listed and shown for illustration purposes only, and are not available individually as replacement parts.